

CAOC

90° Angle head

MADAULA
creative solutions

Technical Data

Caractéristiques techniques / Technische Daten

	ER-11 / 7 mm
R.P.M max	4.000
	3,5 Kg
	1:1
KW	1 Kw
Nm max	4 Nm
Rotation	in = out

L / H

Other measures under request

Autres mesures sur demande

Weitere Maßnahmen auf Anfrage

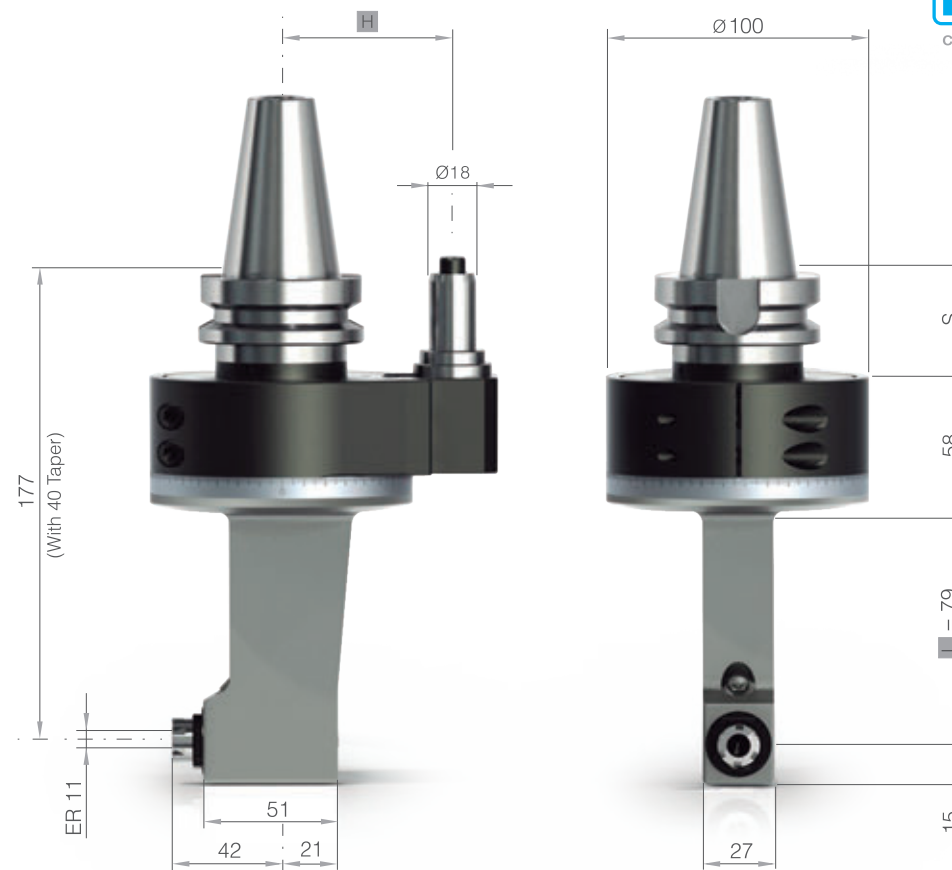
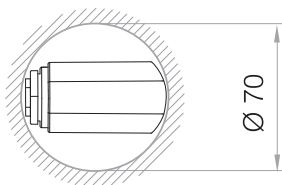

Taper

Cône / Kegel

Size

Taille / Größe

H

S

Taper	Size	H	S
DIN 69871 / 2080	30/40/50	55/65/80	40
CAT	30/40/50	55/65/80	40
MAS-BT	30/40/50	55/65/80	40/40/50
HSK	50/63/100	55/65/80	40/40/50
CAPTO	C5/C6/C8	55/65/80	40/40/50
KM	50/63/100	55/65/80	40/40/50

Standard Equipment

Standard / Standard

Optional Equipment

Optionel / Option

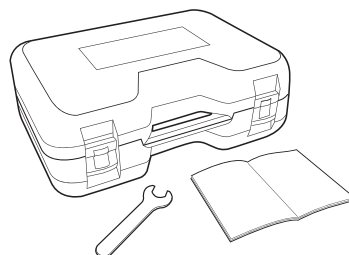

Stop Block

Bloc d'arrêt / Anschlag-Block

See page 51



Collets

Pinces / Spannzangen

See page 52



Coolant through index pin

Arrosage par le doigt d'indexage / Kühlmittelzufuhr durch bolzen

High speed option RPM max

Haute vitesse en option RPM / Hochgeschwindigkeit optional UPM max

6.000